

HAKKO 472D

DESOLDERING TOOL

Desoldering Tool

Instruction Manual

Thank you for purchasing the Hakko 472D desoldering tool with digital temperature display.

Please read this manual before operating the Hakko 472D. Keep this manual readily accessible for reference.



Before Plugging In!

REMOVE the pump securing screw (M4 × 25, red) from the bottom of the 472D station before using it. Leaving the screw in place will cause serious problems. Be sure to **SAVE THIS SCREW!**

REPLACE the pump securing screw (M4 × 25, red) into the bottom of the 472D station before transporting it. Leaving the screw out will cause serious problems.

TABLE OF CONTENTS

PACKING LIST / SPECIFICATIONS	1
WARNINGS, CAUTIONS, NOTES AND EXAMPLES	2
PART NAMES	3
OPERATION	4
PARAMETER SETTING	8
MAINTENANCE	9
REPLACEMENT PARTS	12
ERROR MESSAGES	14
BEFORE SERVICING	14
REPLACEMENT/OPTIONAL PARTS	15
PARTS LIST (IRON)	16
PARTS LIST (STATION)	17
WIRING DIAGRAM	19

PACKING LIST

Please check to make sure that all the items listed below are included in the Hakko 472D package.

Station	1	Cleaning pin for $\phi 1.0$ mm (0.04 in.) nozzle	1
Desoldering iron (Hakko 807)	1	Cleaning pin for heating element	1
Filter pipe [w/filter holder, spring filter & ceramic paper filter (L)]	1	Iron holder	1
Spring filter	3	Instruction manual	1
Ceramic paper filter (S)	2	Control card	1
Ceramic paper filter (L)	4	Card chain	1

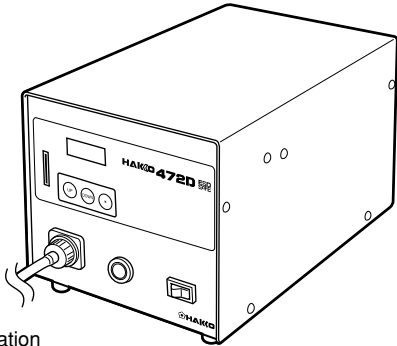

Station

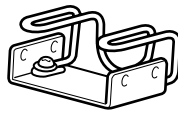

Iron holder

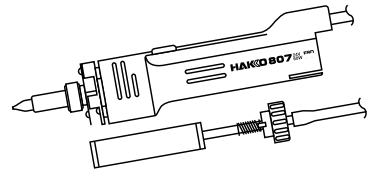

Desoldering iron (Hakko 807)

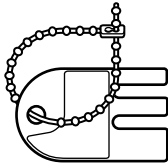

Control card/Card chain

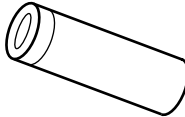

Filter pipe

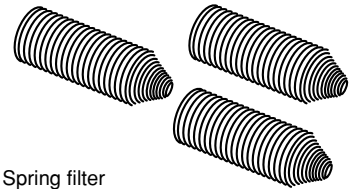

Spring filter

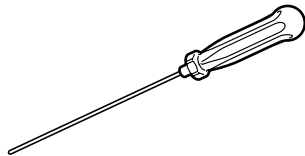

Cleaning pin for heating element

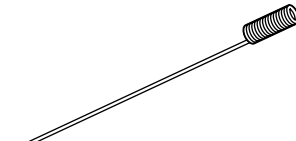

Cleaning pin for $\phi 1.0$ mm (0.04 in.) nozzle

Ceramic paper filter (S)

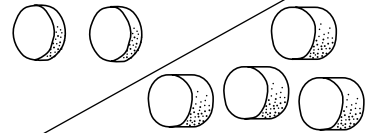

Ceramic paper filter (L)

SPECIFICATIONS

Station	Hakko 472D
Power consumption	120V AC, 110W
Vacuum pressure	80 KPa (600 mmHg)(24 in.Hg)
Suction flow	15 liters/min
Nozzle to ground potential	Under 2 m V
Nozzle to ground resistance	Under 2 Ω
Outer dimensions (l x w x h)	263 x 160 x 148 mm (10.4 x 6.3 x 5.8 in.)
Weight (w/o cord)	4.6 kg (10.14 lb.)

Desoldering iron	Hakko 807
Power consumption	24V AC, 60W
Temperature range	350-450°C (662-842°F)
Total length (w/o cord)	205 mm (8.07 in.)
Weight (w/o cord)	Aprox. 160 g (0.35 lb.)

WARNINGS, CAUTIONS, NOTES AND EXAMPLES

Warnings, cautions and notes are placed at critical points in this manual to direct the operator's attention to significant items. They are defined as follows:

 **WARNING:** Misuse may potentially cause death of, or serious injury to the user.

 **CAUTION:** Misuse may potentially cause injury to the user or physical damage to the objects involved.

For your own safety, be sure to comply with these precautions.

NOTE: A NOTE indicates a procedure or point that is important to the process being described.

EXAMPLE: An EXAMPLE is give to demonstrate a particular procedure, point or process.

CAUTION

Remove the pump securing screws (M4×25 marked red) from the bottom of the station. Failure to do so may result in serious problems. Be sure to save this screw.

When the power is on, the nozzle temperature will be between 350°C/662°F and 450°C/842°F.

Since mishandling may lead to burns or fire, be sure to comply with the following precautions.

- Do not touch the metallic parts near the nozzle, nearby plastic parts and the iron holder .
- Do not use the product near flammable items.
- Advise other people in the work area that the unit can reach a very high temperature and should be considered potentially dangerous.
- Turn the power off when no longer using the Hakko 472D or leaving it unattended.
- Before replacing parts or storing the unit, turn the power off and allow the unit to cool to room temperature.

To prevent accidents and failures, be sure to take the following precautions:

- Do not use the unit for applications other than desoldering.
- Do not rap the desoldering iron against the work bench to shake off residual solder, or otherwise subject the iron to severe shocks.
- Do not modify the unit.
- Use only genuine Hakko replacement parts.
- Do not wet the unit or use the unit with wet hands.
- Set the ceramic paper filter (S) for the filter retainer (station), and the ceramic paper filter (L) for the filter pipe (Iron).
- Maintain the desoldering gun and the station.
- While using the unit, don't do anything which may cause bodily harm or physical damage.

PART NAMES

● Station

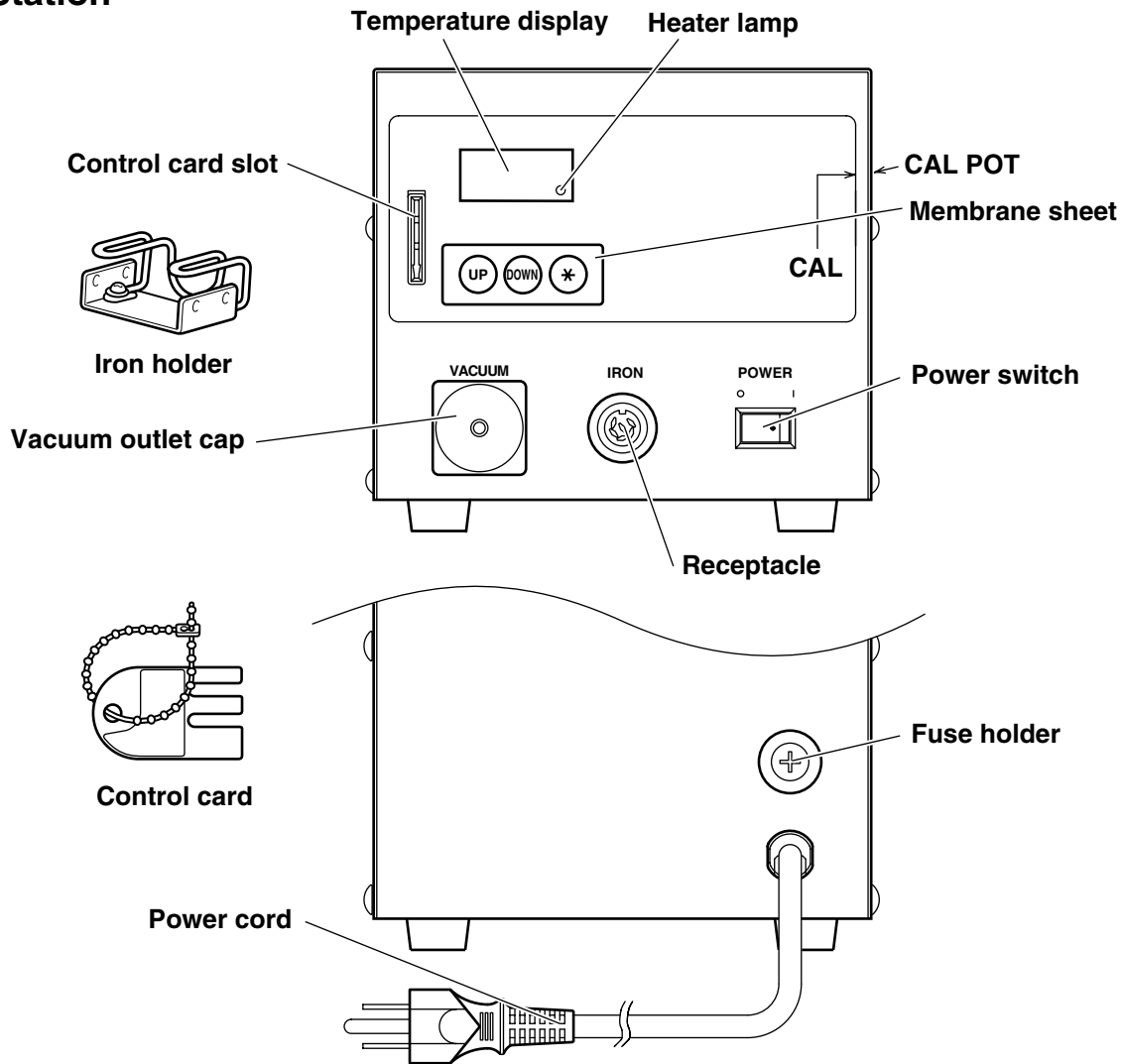

● Desoldering iron

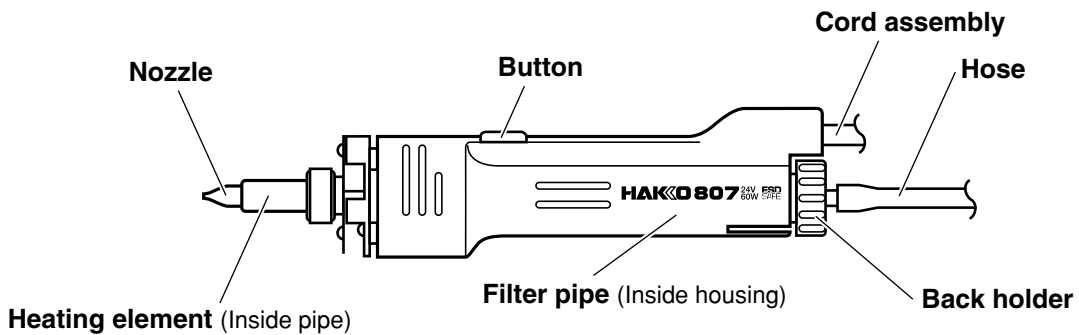

OPERATION

● Attach the iron holder.

Remove the iron holder mounting screws from the side of the station.

Attach the iron holder to the station.

(Figure 1)

(The iron holder can be installed on the either the left or right side.)

● Attach the desoldering iron.

1. Insert the filter pipe (with a filter holder, spring filter and ceramic paper filter (L)) into the housing.

Push and turn the back holder clockwise.

(Figure 2)

2. Connect the cord assembly of the Hakko 807 to the receptacle. (Figure 3)

3. Connect the hose to the vacuum outlet cap. (Figure 4)

4. Set the iron in the iron holder. (Figure 5)

5. Plug the power cord into the power supply and turn the power switch to ON (I).

⚠ CAUTION:

Be sure the power switch is OFF (O) before connecting the desoldering iron cord. Failure to do so may result in damage to circuit board.

● Desoldering

1. Set the temperature.

(Refer to P.6)

NOTE:

Always set the temperature as low as possible for the work being done.
The temperature can be adjusted between 350 – 450°C (662 – 842°F).

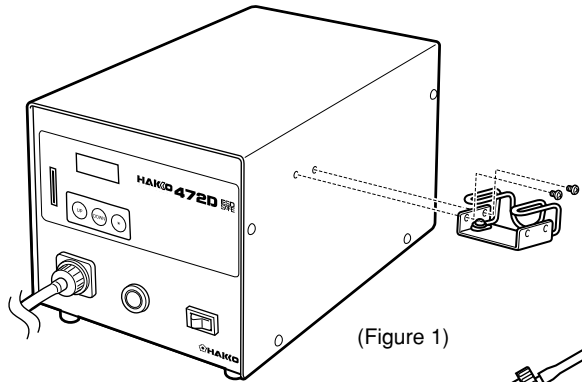

(Figure 1)

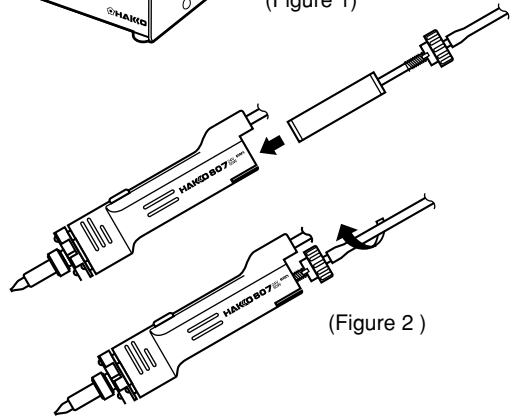

(Figure 2)

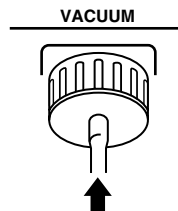

Attach the hose securely over the vacuum outlet cap.

(Figure 4)

Insert the cord assembly by keying the plug to the key on the receptacle.

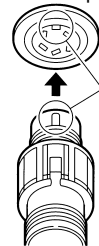

Secure the plug by turning it clockwise.

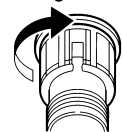

(Figure 3)

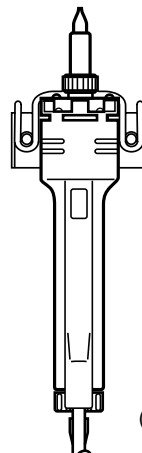

(Figure 5) Top view

⚠ CAUTION

When not in use, place the iron on the iron holder.

OPERATION

2. Clean the tip of the nozzle.

Keep the tinned section of the nozzle clean and shiny by coating it with a small amount of solder.

If the tip of the nozzle is coated with oxide, the nozzle's heat conductivity will be lowered. Coating the tip with a small amount of fresh solder ensures maximum heat conductivity.

NOTE:
The cleaner is not included.

3. Melt the solder.

- Apply the nozzle to the soldered part and melt the solder.

NOTE:
Never allow the nozzle to touch the board itself.

- Confirm that the solder is melted.

NOTE:
• To confirm that all the solder is melted, observe the inside of the hole and the backside of the P.W.B. If this is difficult to do, try slowly moving the lead with the nozzle if the lead moves, the solder is melted.
• Never move the lead by force.
If it doesn't move easily, the solder is not yet fully melted.

4. Extract the solder.

After confirming that the solder is completely melted, extract the solder by pushing the button on the iron.

NOTE:
Never leave any solder remaining inside the hole in the P.W.B.

5. Problems during desoldering.

If solder remains, resolder the component and repeat the desoldering process.

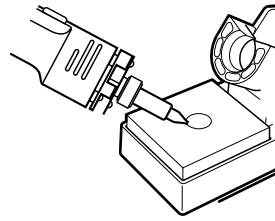

Nozzle cleaner (Optional parts)
Wipe away any oxide or old solder from the nozzle using the hole in the center of the sponge.

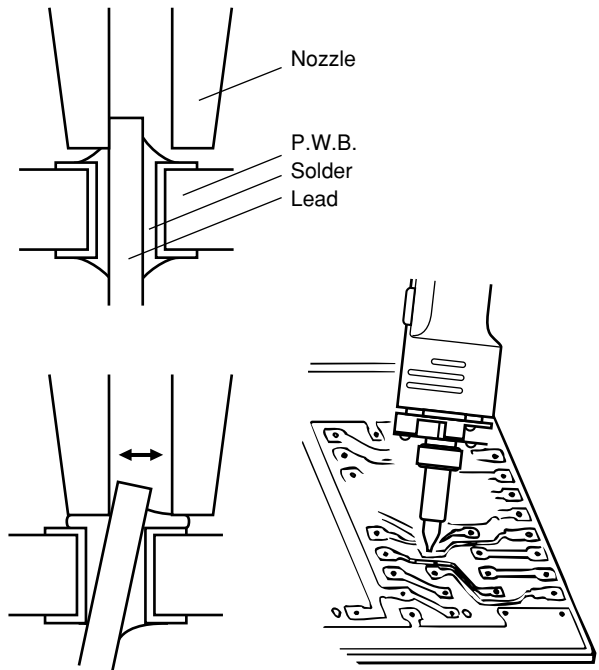

Slowly move the lead with the nozzle.

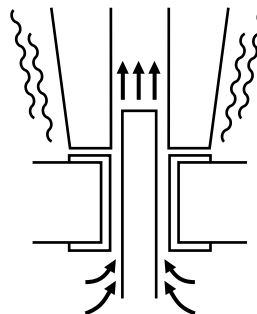

Extract the solder by slowly moving the lead back and forth with the tip of the nozzle.

● Factory setting

The Hakko 472D comes from the factory with the following values preset:

Temperature scale	°F
Low temperature alarm setting	120
Set temperature	750

● Control card

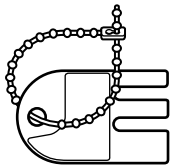

Each Hakko 472D comes with a small card, which inserts in the control slot in the front of the unit. This card is used when entering data for the process control functions. Any Hakko 472D card can be used with any Hakko 472D soldering station.

Using the control card

The control card is used when a value is to be changed or data are to be entered. The Hakko 472D will operate normally with the card inserted. Remove the control card to lock the data.

● Setting/Changing the temperature

1. Insert the card into the card slot in the front panel of the station.

- The HUNDREDS digit in the display begins to flash, indicating that the station is in the temperature setting mode and data can be entered.

2. Enter the HUNDREDS digit

- Use the **UP** or **DOWN** button to select the desired value for the HUNDREDS digit. For setting in degrees Celsius, either 3 or 4 can be selected. For settings in degrees Fahrenheit, values between 6 and 8 can be selected. When the desired value is displayed, press the **ENTER** button.

Example :

Change the temperature from 700°F to 840°F

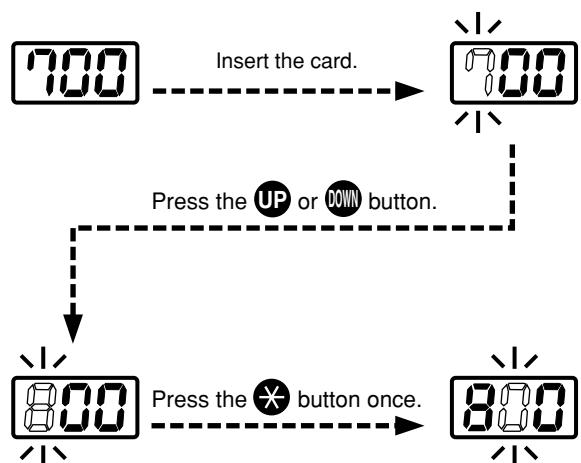

OPERATION

3. Enter the TENS digit

- Press the **UP** or **DOWN** button to select the desired value for the TENS digit. Any value from 0 to 9 can be selected. When the desired value is displayed, press the **✳** button. The UNITS digit begins to flash.

4. Enter the UNITS digit

- Use the **UP** or **DOWN** button to select the desired value for the UNITS digit. Any value from 0 to 9 can be selected. When the desired value is displayed, press the **✳** button. This will store the temperature setting in memory and display the temperature setting. Heater control begins. Remove the card to lock the data.

NOTE:

If the power switch is turned off, or power is lost during the execution of this procedure, no data will be entered. The entire procedure must be repeated from step 1.

When the station is ON (I) and the card is in the station, the data entry procedure follows:

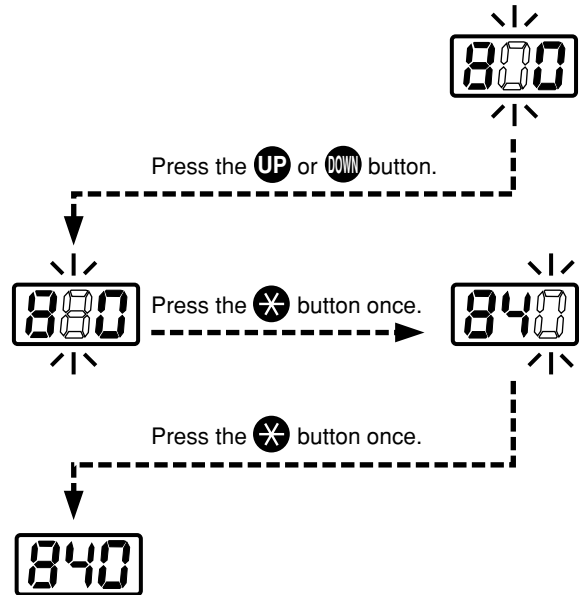

1. Hold the **✳** button down for at least one second.
2. The current temperature setting will be displayed, then the HUNDREDS digit will begin to flash. This indicates that the station has entered the temperature setting mode.
3. Continue with the procedure of 2-4 above.

PARAMETER SETTING

The HAKKO 472D has the following parameters. Parameter settings can be adjusted.

1. °C or °F temperature display selection.
2. Low temperature tolerance.
3. Display of room temperature compensation value (test mode)

Once parameter input mode has been entered, set the parameters in the order shown below. After all the parameters have been set, normal operation will be resumed.

1. °C (Celsius) or °F (Fahrenheit) Temperature Display

1. Turn off the power switch.
2. Insert the control card into the slot in the station.
3. Press and hold the **UP** and **DOWN** buttons simultaneously, then turn on the power switch.
4. Continue holding down the **UP** and **DOWN** buttons until the display shows °C (for Celsius) or °F (for Fahrenheit).
5. When the display shows °C or °F, the station is in parameter input mode.
6. Pressing the **UP** or **DOWN** button will cause °C or °F to be displayed alternately.
7. Press the **✳** button to select the scale. The low temperature tolerance may now be entered.

2. Low temperature tolerance (Flashing of the temperature display)

When the station enters the Low temperature tolerance setting mode, the HUNDREDS digit will begin flashing. Enter and store the value in the same manner as described in 'Changing the temperature setting'.

Range of allowable heater error temperatures

For °C: 30 – 150°C For °F: 60 – 300°F

If a temperature value outside this range is selected, the display will again flash the HUNDREDS digit. If this happens, reenter a correct temperature value.

After setting the low temperature tolerance value, the display will show the room temperature compensation value (test mode).

3. Room Temperature Compensation Value. (Test Mode)

The display will not blink and the heater will not receive power. The room temperature compensation value is the measured temperature of the nozzle. This function will be used later to calibrate the nozzle temperature. (See "Recalibrate the Temperature" on P.13)

No inputs are made here. Press **✳** to complete parameter input. The nozzle temperature setting will be displayed for 2 seconds, after which power will be supplied to the heater and normal temperature control will begin.

MAINTENANCE

Efficient desoldering depends upon the temperature, the quality and quantity of the solder and flux. Perform the following service procedures as dictated by the conditions of the iron usage.

During maintenance, please wear gloves and work carefully.

⚠ WARNING:

Since the desoldering iron can reach a very high temperature, please work carefully. Except when cleaning the nozzle and heating element, always turn the power switch off and disconnect the power plug before performing any maintenance procedure.

Servicing the Desoldering Iron

1. Inspect and clean the nozzle.

- Plug in the power cord, turn the power switch "ON" and let the nozzle heat up.
- Clean out the hole of the nozzle with the nozzle cleaning pin.

If the nozzle cleaning pin does not pass through the nozzle, use the cleaning drill (option).

NOTE:

- The cleaning drill is not included.
- The cleaning pin will not pass through the nozzle until the solder inside the nozzle is completely melted.

- Check the condition of the solder plating, surface and inside hole of the nozzle. If it is slightly worn, recoat the tip with fresh solder.
- If it is worn or eroded, or the inside diameter seems unusually wide, replace the nozzle.

NOTE:

The inside hole and the surface of the nozzle is plated with a special alloy. Should this alloy become eroded by high temperature solder, the nozzle will not be able to maintain the proper temperature.

- If the cleaning pin and cleaning drill do not pass through the hole in the nozzle, replace the nozzle.

Cleaning with the nozzle cleaning pin.

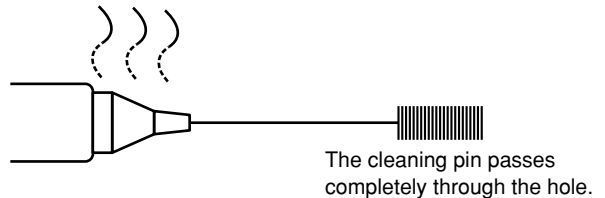

Cleaning with the cleaning drill (option).

• Before cleaning

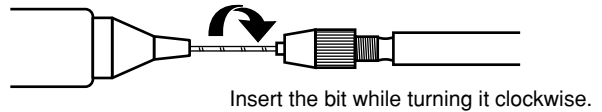

• After cleaning

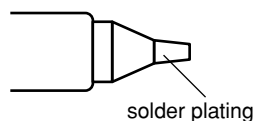
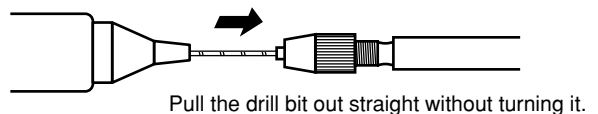

⚠ CAUTION

If the cleaning drill is forced into the nozzle, the drill bit could break or be damaged.

⚠ CAUTION

Please use the proper sized cleaning pin or cleaning drill for the nozzle diameter.

NOTE:

Unfortunately, it is often difficult to observe this condition, therefore, if desoldering efficiency goes down and all other parts appear to be OK, the nozzle is probably eroded and should be replaced.

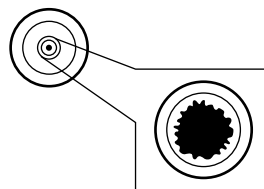

Diameter of hole is widened through erosion.

2. Disassemble the heating element part.

⚠ CAUTION:
The heating element is very hot during operation.

3. Clean out the hole in the heating element.

Be sure the solder in the hole in the heating element is completely melted, then clean the hole with the cleaning pin provided.

If the cleaning pin cannot pass through the hole, replace the heating element.

Cleaning the inside of the filter case

1. Replace the ceramic paper filter (S).

Remove the ceramic paper filter (S) and inspect it. If it is stiff with flux, replace it.

2. Reassemble the filter case.

⚠ CAUTION:
Insert the small ceramic paper filter into the filter retainer at the station. Using the large ceramic paper filter may damage the unit, or reduce the effectiveness of the unit.

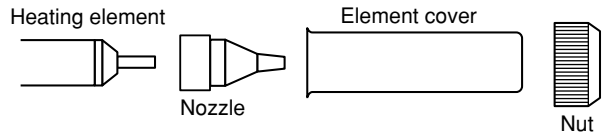

Remove the nut with the spanner.

Scrape away all oxidation from the hole in the heating element until the cleaning pin passes cleanly through the hole.

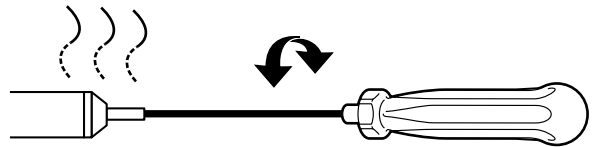

The cleaning pin passes cleanly through the hole.

VACUUM

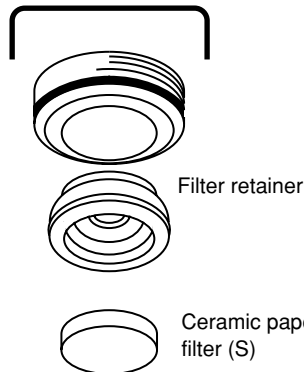

Remove the filter retainer and push out the ceramic paper filter.

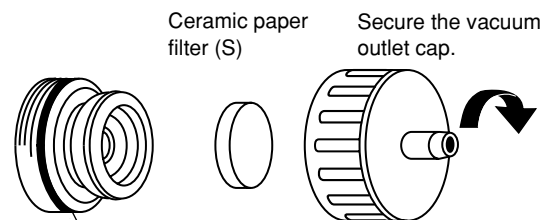

Apply silicone grease to the O-ring (S-20) and securely tighten the vacuum outlet cap to prevent air leakage.

MAINTENANCE

Cleaning the pump

1. Disassemble the pump heads.

- Unplug the power cord.
- Remove the cover screws. (right/left)
- Remove the cover.
- Remove the pump head from each side of the pump.

2. Clean the pump head.

- Remove the valve plate and fixing plate.
- Remove any flux adhering to the plates.
- If the valve plate is bent or stiff, replace it.
- If the exhaust filter is dirty, replace it.

⚠ CAUTION:

- If the fixing plate is difficult to remove, apply hot air to it to warm it up.
- Never use excessive force to remove the plate as it is easy to bend, and a bent plate will allow a leak, which reduces the efficiency of solder extraction.
- Clean the plates only with alcohol or thinner.

3. Assemble the pump heads.

Reassemble the valve plate and fixing plate.

⚠ CAUTION:

When assembling the pump, be sure to check for air leaks.

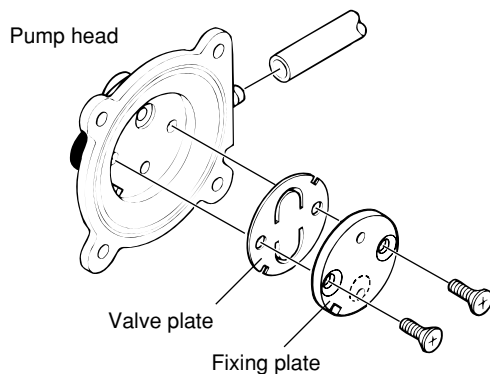
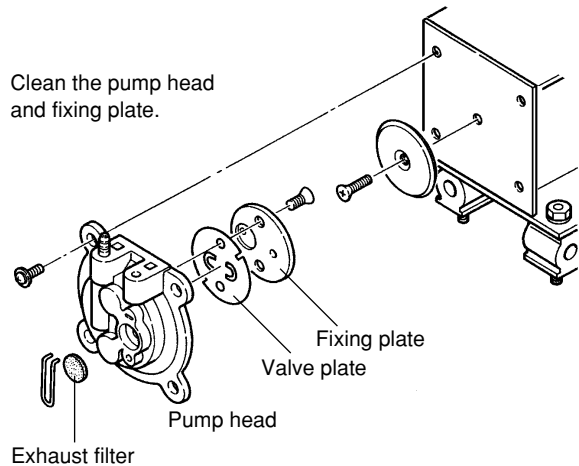

Be sure the parts are aligned correctly.

REPLACEMENT PARTS

● Replacing the filters.

1. Turn the back holder knob counterclockwise and pull out the filter pipe.
2. If there is solder in two-thirds of the spring filter, replace the filter.
3. If the ceramic paper filter is stiff with flux and solder, replace the filter.
4. Insert the spring filter into the filter pipe.
5. Insert the ceramic paper filter and put the back holder into the filter pipe.
6. Insert the filter pipe into the main body and secure it by turning the back holder knob clockwise.

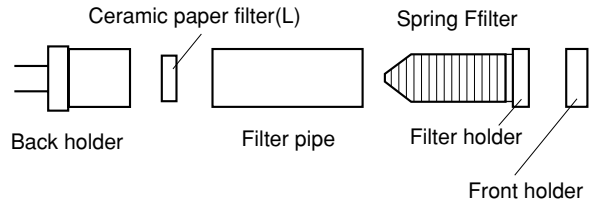

CAUTION
Securely insert the spring filter to the end of the filter holder.

● Replacing the heating element

Check the resistance value

The resistance values of a working heating element are

9.2Ω between pins 1 and 3 (heating element),
54Ω between pins 2 and 4 (sensor) at 73°F (23°C)
If the measured values are outside this range, replace the heating element.

(No. A1174 24V-60W heating element for Hakko 807)

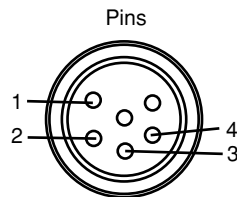

Fig. 1

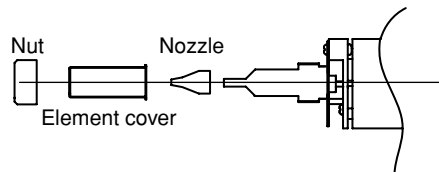

Fig. 2

Replacing the heating element

1. Unplug the cord.
2. Remove the nut, element cover, and nozzle.
3. Turn the back holder knob counterclockwise and pull out the filter pipe.
4. Remove the housing fastener.
5. Remove the screws securing the housing ⑨ and the screws ③ ④ securing the flange to the housing.
6. Remove the front holder.
7. Remove the screw ⑤ ⑥ ⑦ securing the heating element to the flange, and the screw ① ② .

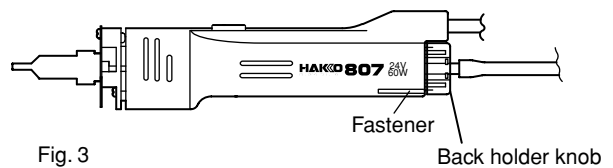

Fig. 3

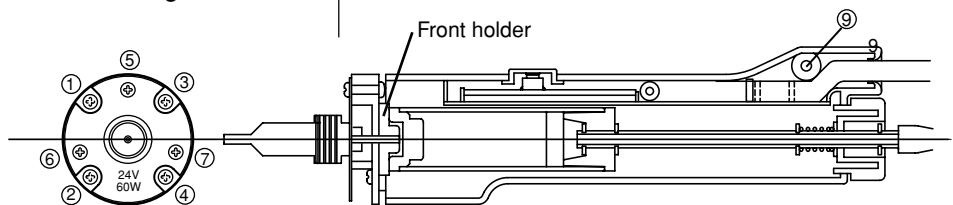

Fig. 4

REPLACEMENT PARTS

8. Desolder the heating element leads (marked H) and sensor leads (marked S).
9. Remove the old heating element and replace it with a new one.
10. Bend the lead wire as shown in Fig. 6, and pass two red leads and two white leads through the holes as shown in Fig. 7.
7. Secure a heating element to the flange with the screws ⑤ ⑥ ⑦.
11. Install the front holder.
12. Resolder the heating element leads (red wires/H) sensor leads (white wires/S).
13. Reassemble the unit.

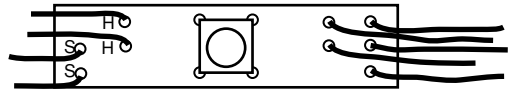

Fig. 5

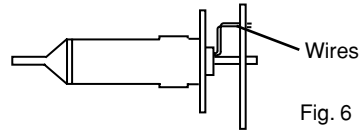

Fig. 6

CAUTION
Be careful not to twist and pull the lead wire when installing the heating element.

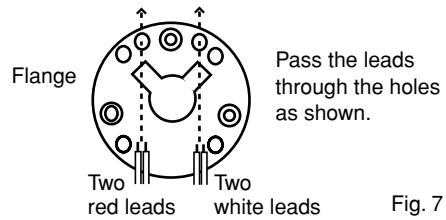

Fig. 7

NOTE:
Be sure the insulation on the leads touches the board. Do not leave any bare wire exposed.

● Recalibrate the temperature

- (a) Set the desire temperature.
- (b) Adjust the temperature calibration pot (CAL) until the nozzle temperature (measured with a tip thermometer) is correct.

ERROR MESSAGES

Various error messages will be displayed when there is a problem with the Hakko 472D unit. If the following message is displayed, refer to “Trouble Shooting Guide”.

--- System Error

After the power has been turned on, the system checks the memory and the programs. If an abnormality is found, **---** will be displayed, and all operations will be completely stopped.

S-E Sensor Error

If there is a possibility of a failure in the sensor or anywhere in the sensor circuit, **S-E** will be displayed and power to the desoldering iron will be cut off.

The sensor error also occurs if the cord assembly is not properly connected.

Low temperature tolerance
(Flashing of the temperature display)

If power is present at the desoldering iron and the nozzle temperature goes below the heater error temperature tolerance setting, the temperature display will flash. This indicates the possibility of a heater malfunction.

EXAMPLE:

Assume the temperature setting is 400°C (750°F) and the low temperature tolerance is 50°C (100°F). If, even though the heater is receiving power, the temperature of the desoldering iron goes below 350°C (650°F) the display will begin to flash indicating a possible heater malfunction.

EXAMPLE:

$400^{\circ}\text{C} - 50^{\circ}\text{C} = 350^{\circ}\text{C}$ ($750^{\circ}\text{F} - 100^{\circ}\text{F} = 650^{\circ}\text{F}$)
→ The display will begin to flash.

NOTE:

If the temperature begins to rise again, the display will stop flashing – even if the displayed temperature is below 350°C (650°F).

BEFORE SERVICING

⚠ WARNING:

- Disconnect the power plug before servicing.
Failure to do so may result in electric shock.
- If the power cord is damaged, it must be replaced by the manufacturer, its authorised service agent, or a similarly qualified technician to avoid hazard.

REPLACEMENT/OPTIONAL PARTS

Replacement and optional parts for Hakko 807

• Nozzle

Part No.	Part name/Description
A1002	Nozzle S ϕ 0.8 mm (0.03 in.) / Small
A1003	Nozzle S ϕ 1.0 mm (0.04 in.) / Small
A1004	Nozzle ϕ 0.8 mm (0.03 in.)
A1005	Nozzle ϕ 1.0 mm (0.04 in.)
A1006	Nozzle ϕ 1.3 mm (0.05 in.)
A1007	Nozzle ϕ 1.6 mm (0.06 in.)

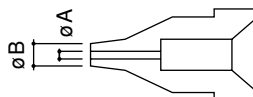

Part No.	ϕ A	ϕ B
A1487	0.6 mm (0.023 in.)	1.5 mm (0.059 in.)
A1002	0.8 mm (0.03 in.)	1.8 mm (0.07 in.)
A1003	1.0 mm (0.04 in.)	2.0 mm (0.08 in.)
A1393	1.0 mm (0.04 in.)	1.4 mm (0.055 in.)
A1395	1.3 mm (0.05 in.)	2.1 mm (0.083 in.)

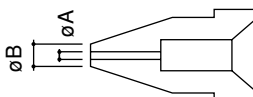

Part No.	ϕ A	ϕ B
A1004	0.8 mm (0.03 in.)	2.3 mm (0.09 in.)
A1005	1.0 mm (0.04 in.)	2.5 mm (0.1 in.)
A1006	1.3 mm (0.05 in.)	3.0 mm (0.12 in.)
A1007	1.6 mm (0.06 in.)	3.0 mm (0.12 in.)
A1396	2.3 mm (0.09 in.)	3.8 mm (0.15 in.)

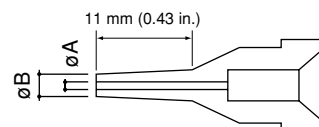

Part No.	ϕ A	ϕ B
A1394	1.0 mm (0.04 in.)	2.1 mm (0.083 in.)

• Cleaning Pin/Drill

Part No.	Part name/Description
B1215	Cleaning pin for heating element
B1086	Cleaning pin for ϕ 0.8 mm (0.03 in.) nozzle
B1087	Cleaning pin for ϕ 1.0 mm (0.04 in.) nozzle
B1088	Cleaning pin for ϕ 1.3 mm (0.05 in.) nozzle
B1089	Cleaning pin for ϕ 1.6 mm (0.06 in.) nozzle
B1302	Cleaning drill for ϕ 0.8 mm (0.03 in.) nozzle
B1303	Cleaning drill for ϕ 1.0 mm (0.04 in.) nozzle
B1304	Cleaning drill for ϕ 1.3 mm (0.05 in.) nozzle
B1305	Cleaning drill for ϕ 1.6 mm (0.06 in.) nozzle

Spanner, cleaning brush, silicone grease, iron holder

Part No.	Part name/Description
B2100	Spanner (for desoldering iron)
B1670	Cleaning brush
A1028	Silicone grease
C1316	Iron holder for Hakko 807

PARTS LIST (Iron)

NOTE:

Spare or repair parts do not include mounting screws, if they are not listed on the description.
Screws must be ordered separately.

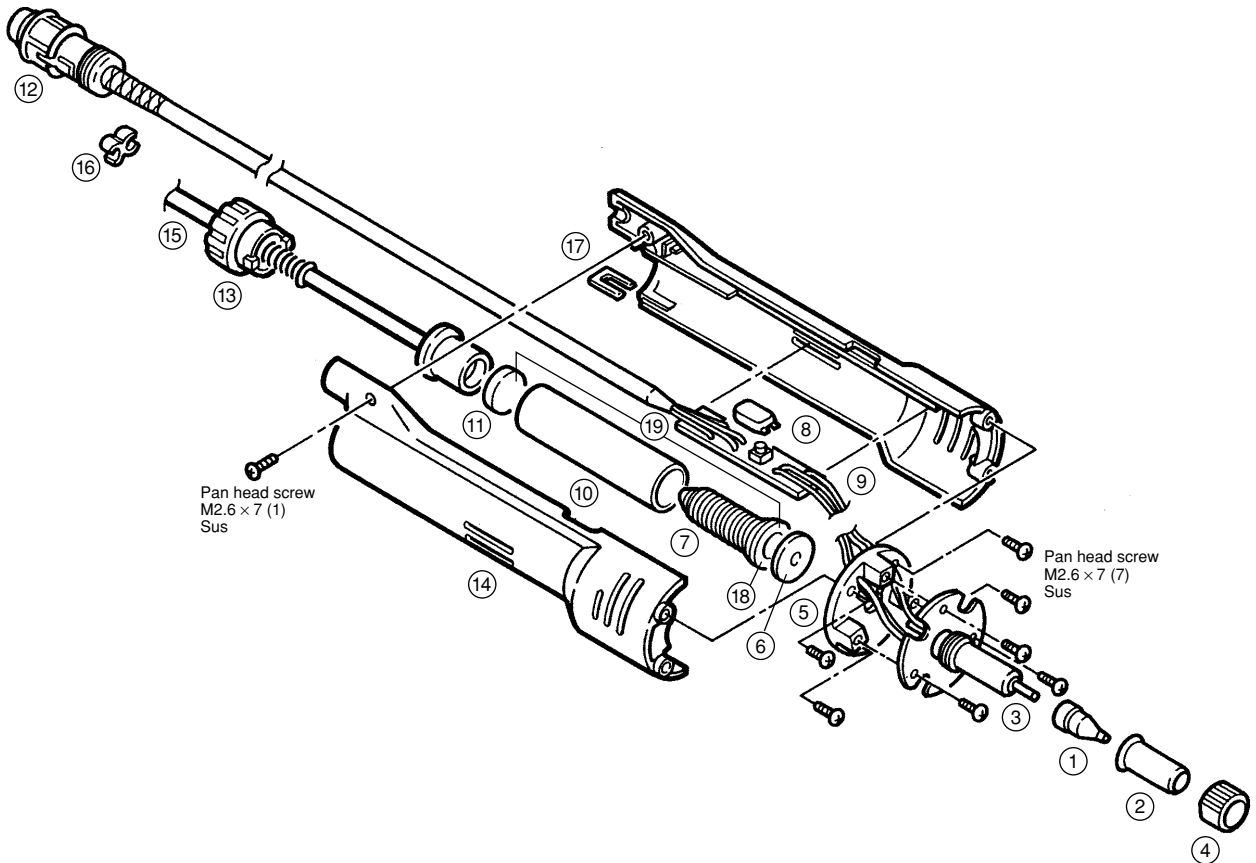

Item No.	Part No.	Part Name	Description
1		Nozzle	See P.15
2	B1653	Element cover	
3	A1174	Heating element	24V-60W
4	B1015	Nut	
5	B1654	Flange	
6	A1304	Front holder	
7	A1030	Spring filter	Set of 10
8	B1655	Button	
9	B1656	Board	With switch
10	B1916	Filter pipe	
11	A1033	Ceramic paper filter (L)	Set of 10
12	B1657	Cord assembly	
13	B1917	Back holder assembly	
14	B1659	Housing	With a screw & fastener
15	B1023	Hose	
16	B1024	Cord holder	Set of 4
17	B1660	Housing fastener	
18	B1915	Filter holder	
19	B2517	Filter pipe asse'y	With filter holder & filters

PARTS LIST (Station)

NOTE:
Spare or repair parts do not include mounting screws, if they are not listed on the description.
Screws must be ordered separately .

● 472D Station

Item No.	Part No.	Part Name	Description
1	B1029	Vacuum outlet cap	
2	A1009	Ceramic paper filter (S)	Set of 10
3	B1063	Filter retainer	
4	B1034	O-ring	S-20
5	B1031	Vacuum outlet retainer	With O-ring & screws
6	B1064	Filter case joint	
7	B1662	Receptacle	
8	B1084	Power switch	
9	B1204	Rubber foot	
10	B2724	Chassis	With rubber foot
11	B2314	Hose assembly	
12	B2726	P.W.B. for display	
13	B2727	P.W.B. for heat control	
14	B2047	Membrane sheet	
15	B2388	Control card	
16	B2444	Pump assembly	
17	B2728	Transformer	
18	B1041	Fuse holder	
19	B1275	Fuse	250V-2A (U)
20	B2068	Power cord, 3 core & American plug	
21	B2725	Cover	
22	B2729	Iron holder	
23	B1053	Balance weight	
24	B1312	Crank	
25	B2506	Damper	Set of 2
26	B1057	Ring for bearing	
27	B2060	Crank shaft	With screw
28	B2059	Pump flame	
29	B2058	Motor	
30	A1013	Diagram	Set of 2, with screws
31	B2085	Diagram setting plate	
32	B1056	Fixing plate	
33	A1014	Valve plate	Set of 2
34	B1050	Pump head	With screws
35	B1059	Exhaust filter	Set of 2
36	B1313	Filter retaining pin	

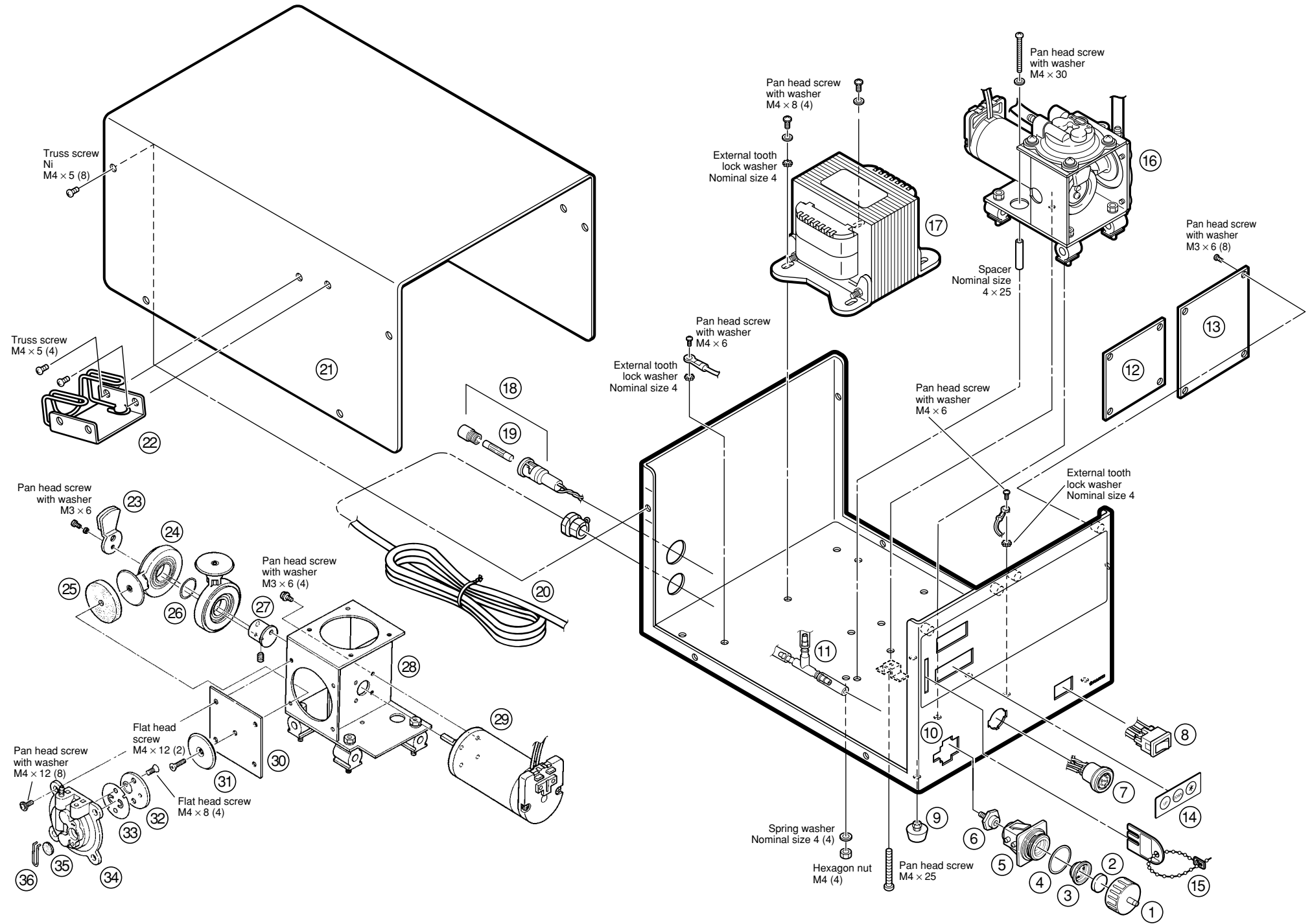

WIRING DIAGRAM

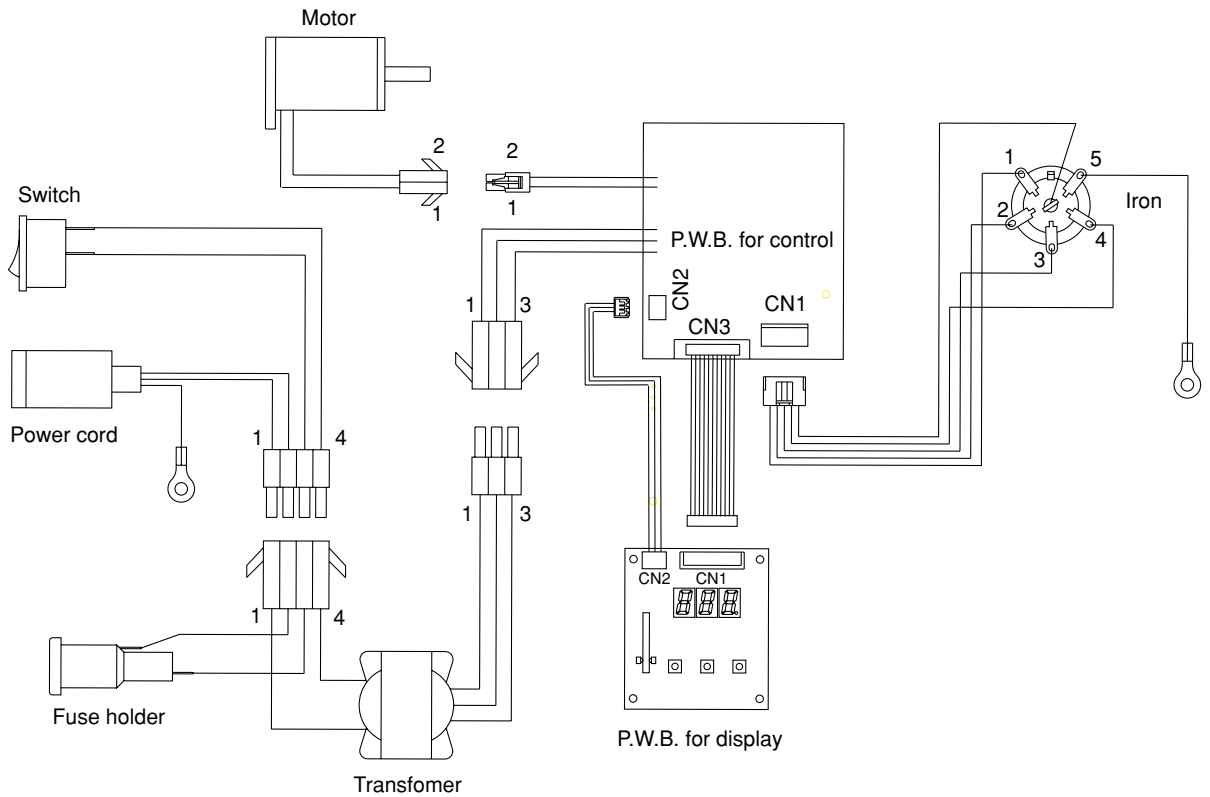

HAKKO CORPORATION

HEAD OFFICE

4-5, SHIOKUSA 2-CHOME, NANIWA-KU, OSAKA, 556-0024 JAPAN

TEL:+81-6-6561-3225 FAX:+81-6-6561-8466

<http://www.hakko.com/>

AMERICAN HAKKO PRODUCTS, INC.

28920 N. AVENUE WILLIAMS VALENCIA CA 91355, U.S.A.

TEL: (661) 294-0090 FAX: (661) 294-0096

Toll Free (800)88-HAKKO www.hakkousa.com